

Valves

CHECK VALVE



NEEDLE VALVE

67

VALVE MANIFOLDS

81

BALL VALVE

90

CHECK VALVE

104

MCV MINI IN LINE CHECK VALVE

FEATURES

- 316 St. St. End Brass Construction
- Moderate Pressure Characteristics (up to 3000psi)
- Compact Design
- Interchangeable Parts
- Variable fixed cracking-pressure springs

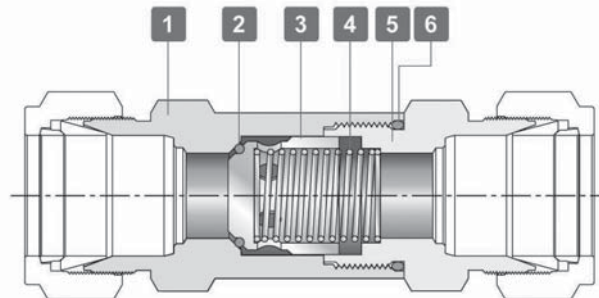
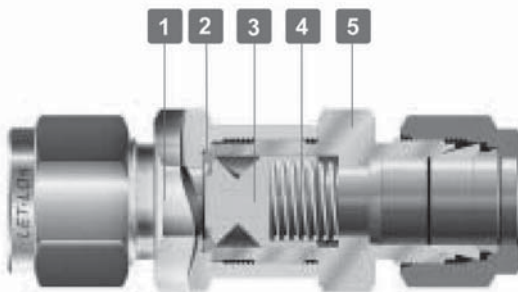
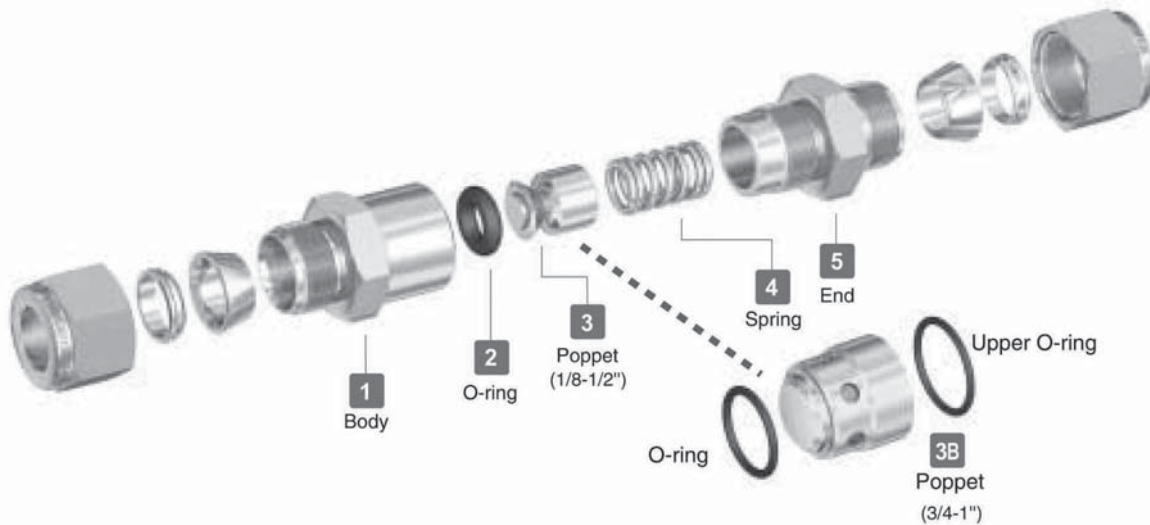

MCV - MATERIALS SIZE 1/8''-1/2''		
Item No.	Components	Valve Body Material
1	Body	A.I.S.I 316
2	O-ring	Viton®
3	Poppet	A.I.S.I 316
4	A Spring 1/3 psi	A.I.S.I 302
	B Spring 3 psi	A.I.S.I 302
	C Spring 10 psi	A.I.S.I 302
	D Spring 25 psi	A.I.S.I 302
5	End	A.I.S.I 316

MCV - MATERIALS : SIZE 3/4''-1''		
Item No.	Components	Valve Body Material
1	Body	A.I.S.I 316
2	O-ring	Viton®
3B	Poppet	A.I.S.I 316
4	A Spring 1/3 psi	A.I.S.I 302
	B Spring 3 psi	A.I.S.I 302
	C Spring 10 psi	A.I.S.I 302
	D Spring 25 psi	A.I.S.I 302
5	End	A.I.S.I 316
6	Upper O-ring	Viton®

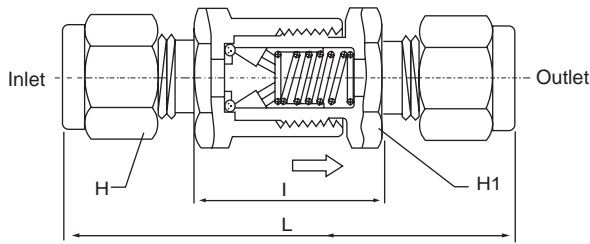

Dimensions	1/8	1/4	3/8	1/2	3/4	
Abbreviation	01	02	03	04	06	
BSP	Pipe Diameter	1/8	1/4	3/8	1/2	3/4
	Name	01	02	03	04	06
Metric	Pipe Diameter	6mm	8mm	10mm	12mm	14mm 16mm 18mm 20mm 22mm
	Name	60D	80D	100D	120D	140D 160D 180D 200D 220D

TECHNICAL DATA

End Connection Dimension	1/8", 1/4", 6mm, 8mm	3/8", 1/2", 10mm, 12mm	4/3", 14mm, 16mm, 1.8mm, 20mm, 22mm
Max. Working Pressure	3000-6000PSI		Brass: 1500PSI(10.300kpa) SS 316 2000PSI(13.700kpa)
Temperature Range	Vito:-23°C - 191°C(-10°F - 375°F) NBR:-23°C - 121°C(-10°F - 375°F)		
Check Pressure	1. 10. 25PSI(2. 6. 66. 170kpa) Selection: Spring with Cracking Pressure up to 100PSI		
Liquid Coefficient	1/8" - 0.16 1/4" - 0.6mm, 8mm - 0.47	3/8" - 1.47 1/2" - 10mm, 12mm - 1.68	4.48

Attention: Don't use for the high burst pressure or in the

Name	Liquid	End Connection			Dimension				
No.	Diameter	CMB	Inlet	Outlet	L	I	H	H1	
MCV -01M(N)	4.8	0.47	1/8 (N)PT	1/8 (N)PT	50.5	30.5	--	19.00	
MCV -01F(N)		0.47	1/8 (N)PT	1/8 (N)PT	54	30.5	--		
MCV -01OD		0.16	1/8OD	1/8OD	54	30.5	12.00		
MCV -02M(N)		0.47	1/4 (N)PT	1/4 (N)PT	56.5	30.5	--		
MCV -02OD		0.47	1/4OD	1/4OD	66	30.5	14.00		
MCV -60D		0.47	6mmOD	6mmOD	65	30.5	14.0		
MCV -02F(N)	4.8		1/4 (N)PT	1/4 (N)PT	60.5	30.5	--	19.00	
MCV -03M(N)			3/8 (N)PT	3/8 (N)PT	60.5	30.5	--		
MCV -03OD		0.47	3/8OD	3/8OD	67.2	30.5	17.00		
MCV -80D			8mmOD	8mmOD	67.2	30.5	17.00		
MCV -100D			10mmOD	10mmOD	69.2	30.5	19.00		
MCV -03F(N)				3/8 (N)PT	3/8 (N)PT	60.5	59.2		--
MCV -04M(N)	16.0		1/2 (N)PT	1/2 (N)PT	93	59.2	--		
MCV -04OD			1/2OD	1/2OD	104	59.2	22.00		
MCV -120D			12mmOD	12mmOD	104	59.2	22.00		
MCV -04F(N)				1/2 (N)PT	1/2 (N)PT	93	59.2	--	
MCV -06M(N)				3/4 (N)PT	3/4 (N)PT	97	59.2	--	
MCV -06F(N)		5.2		3/4 (N)PT	3/4 (N)PT	95	59.2	--	32.00
MCV -06OD			3/4OD	3/4OD	110.7	59.2	28.58	32.00	
MCV -140D			14mmOD	14mmOD	81	59.2	27		
MCV -160D			16mmOD	16mmOD	81	59.2	27		
MCV -180D			18mmOD	18mmOD	110	59.2	27		
MCV -200D			20mmOD	20mmOD	81.5	59.2	32		
MCV -220D			22mmOD	22mmOD	81.5	59.2	32		

All dimensions are in millimeters unless otherwise specified, only for reference subject to change.

ORDERING INFORMATION

MCV	01	M	(N)
Group	Thread Size	Connection Type	Thread Type
MCV= MINI IN LINE CHECK VALVE	01=1/8" 08=1" 14=14mm 02=1/4" 6=6mm 16=16mm 03=3/8" 8=8mm 18=18mm 04=1/2" 10=10mm 20=20mm 06=3/4" 12=12mm 22=22mm	M=Male F=Female OD=Tube End	N=NPT

LCV IN-LINE CHECK VALVE

FEATURES

- 316 St. St. End Brass Construction
- Moderate Pressure Characteristics (up to 3000psi)
- Compact Design
- Interchangeable Parts
- Variable fixed cracking-pressure springs

LCV-HP - MATERIALS		
Item No.	Components	Valve body material
1	Body	St.St. ASTM A-276
2	Poppet	Viton Bonded on 316 St.St.
3	Pusher	St.St. ASTM A-276
4	Spring	St.St. 304
5	O-ring	Viton®
6	Back Up	Viton®
7	End	St.St. ASTM A-276
8	Front Ferrule	St.St. ASTM A-276
9	Back Ferrule	St.St. ASTM A-276
10	Nut	St.St. ASTM A-276

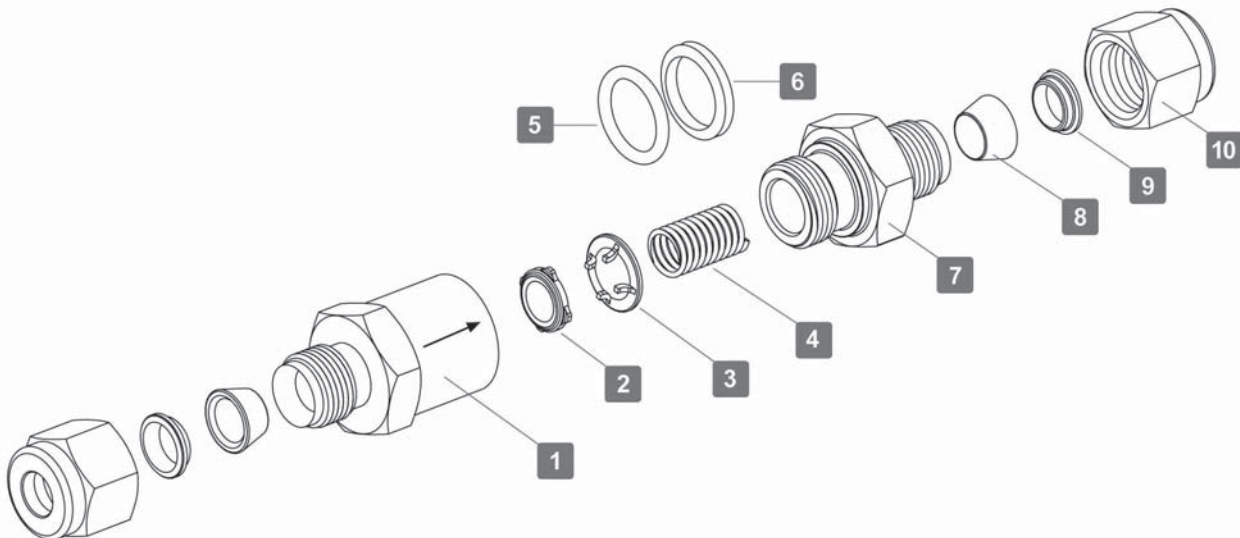
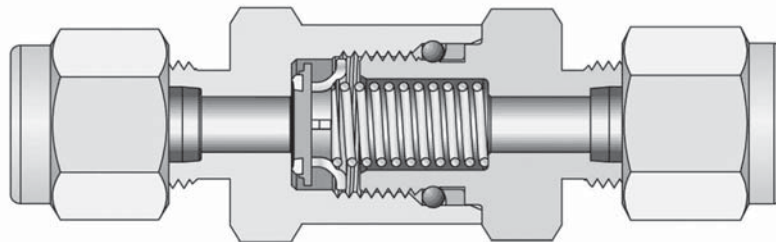

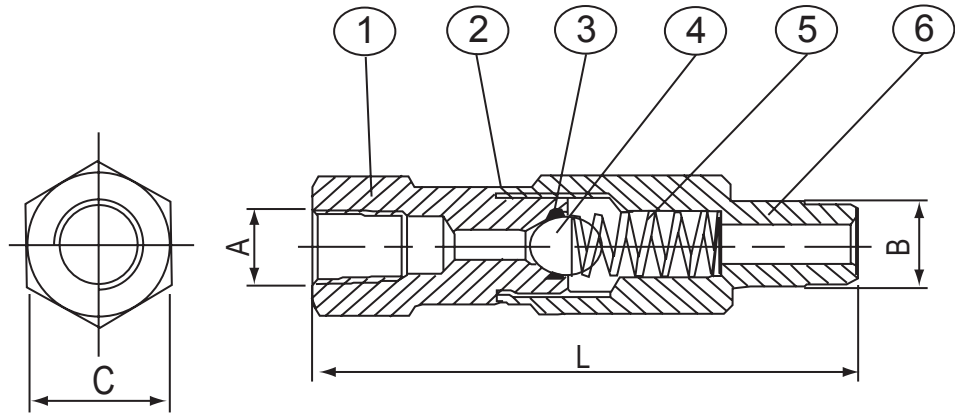

6000PSI PRESSURE RATING

SPECIFICATINONS

No.	PART	SS316 VALVE	BRASS
1	VALVE BODY(INLET)	SS316	BRASS
2	PACKING	SS316	BRASS
3	O-RING	VITON/BUNA	VITON/BUNA
4	BALL	SS304	SS304
5	SPRING	SS304	SS304
6	VALVE BODY(OUTLET)	SS316	BRASS

DIMENSIONS(INCH)

Name	SIZE	A SIDE PT/NPT/G	B SIDE PT/NPT/G	C(mm)	D(mm)
LCV-01	1/8"	1/8"	1/8"	19	74
LCV-02	1/4"	1/4"	1/4"	19	74
LCV-03	3/8"	3/8"	3/8"	22	74
LCV-04	1/2"	1/2"	1/2"	27	75.5
LCV-06	3/4"	3/4"	3/4"	35	83.5
LCV-08	1"	1"	1"	41	87.5

Could order Double-Female and Tube End or other method as special required.

ORDERING INFORMATION

